

15" TFT LCD Display

Medical Application



Where Versatility Meets Flexibility

MA15BX

Configuration		MA15BX
LCD Display		15" TFT active matrix panel
Pixel Pitch		0.297 (H) x 0.297 (V) mm
Max. Resolution		XGA 1024 x 768
Contrast Ratio		700:1 (Typ.) <small>w/o sensor or glass</small>
Brightness		225 cd/m ² (Typ.) <small>w/o sensor or glass</small>
Response Time (Tr+Tf)		8 ms (Typ.)
Display Color		16.2M
Effective Display Area		304.1 (H) x 228.1 (V) mm
Viewing Angle (CR ≥ 10)		140°(H) x 130°(V) (Typ.) <small>w/o sensor or glass</small>
Lamp Life (hr) / Backlight		35,000 (Typ.) / CCFL
Stand Base		Tilt down : -5°, Tilt up : +90°
Input Signals		Analog, Digital
Signal Connector	Analog Digital	D-Sub15 pin (VGA) DVI-D
Scan Frequency		60 ~ 75 Hz
Audio System		1W / per channel driver
Touch Panel		5 wire Resistive
Touch Interface		RS-232 x1 or USB A type x1
Key Control		Power on/off, with LED, Menu, Select, Adjustment (+,-)
Power		Universal Power Adapter Input AC 100~240V, 50~60 Hz Output DC 12V / 4.2A, 50W
Operating Condition	Temperature Humidity Altitude	0°C - 40°C (32°F - 104°F) 10% - 90% (no condensation) To 10,000 feet
Storage Condition	Temperature Humidity	-20°C - 60°C (-4°F - 140°F) 10% - 90% (no condensation)
Dimensions (WxHxD)		351.0 x 314.5 x 140.0 mm
Carton Dimensions (WxHxD)		438.0 x 460.0 x 214.0 mm
Weight (Net)		4.5 kg
Certification		CE, FCC, UL60601-2.0

* Specifications are subject to change without notice.

Features

- ⊙ High contrast color TFT LCD display support resolution up to 1024 x 768. Compatible with IBM, VGA, VESA standards.
- ⊙ Support DDC 1/2B for Plug & Play compatibility.
- ⊙ Advanced OSD control for picture quality adjustment.
- ⊙ Auto detects multi-signals input.
- ⊙ Optional front panel sealed to resist dust and splashes.
 - AG / AR tempered glass : IP54
 - Resistive / Capacitive Touch Panel : IP54
- ⊙ VESA mounting.
- ⊙ RoHS Compliance.

Optional Accessories

- ⊙ Anti-Glare / Anti-Reflective tempered glass (MOQ) .
- ⊙ Capacitive Touch Solution (MOQ) .
- ⊙ Choice of black or white housing (MOQ) .
- ⊙ Video Signal input (MOQ) .
 - Signal Connector : RCA / S-Video
 - NTSC / PAL / SECAM video systems compatible .

I / O Port

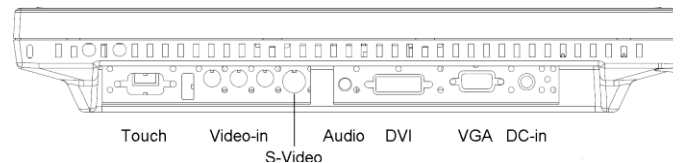

Mechanical Drawing

Unit : mm

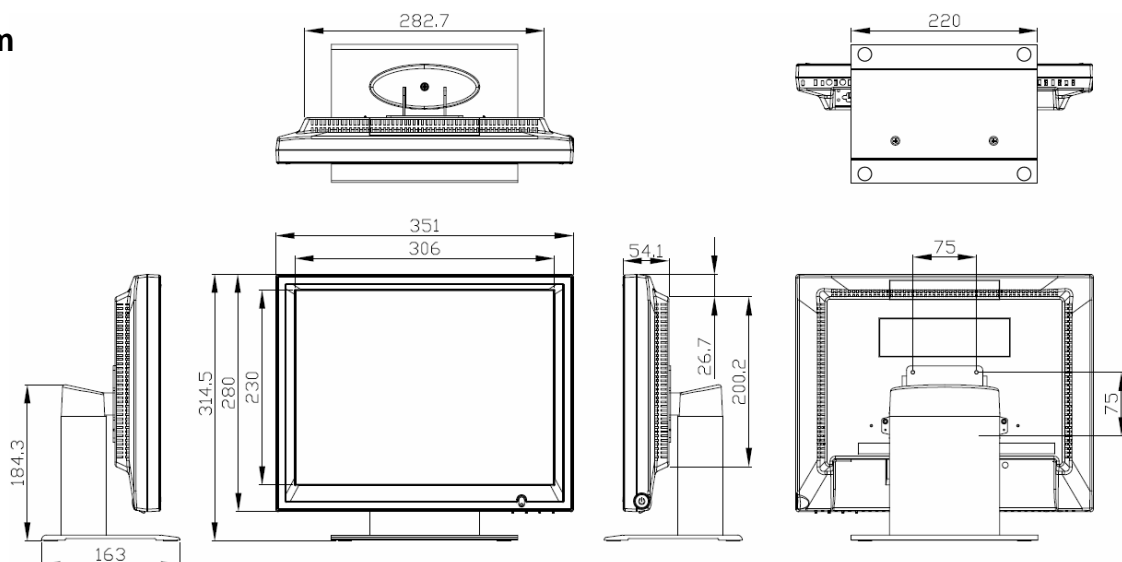

For more information please contact

Tel:+886-2-2264-1991 | Fax:+886-2-2264-7535 | www.GVISION.com.tw