



GVISION Medical Desktop Monitor

MA17BH

**17" Medical Desktop Monitor
with Optional Touchscreen**



The MA17BH is GVision's a 17" medical monitor for hospital applications. Designed for medical use, GVISION monitors with optional touchscreen can be easily integrated into a multitude of solutions; healthcare applications such as nursing stations, computer-aided therapy, electronic medical record keeping, paperless charting, patient self-check-in / registration or point-of-information installations. GVISION medical monitors are fully certified with UL 60601. Touch technology can be customized for your projects.



- Customizable video inputs
- UL 60601 certified

For more information please contact

1-888-651-9688 | www.GVISION-USA.com

Where Versatility Meets Flexibility



PARAMETER		SPECIFICATION
LCD Display		17" TFT active matrix panel
Pixel Pitch		0.264 (H) x 0.264 (V) mm
Max. Resolution		SXGA 1280 x 1024
Contrast Ratio		1000:1 (Typ.) w/o sensor or glass
Brightness		350 cd/m2 (Typ.) w/o sensor or glass
Response Time (Tr+Tf)		8 ms (Typ.)
Display Color		16.7M
Effective Display Area		337.9 (H) x 270.3 (V) mm
Viewing Angle (CR 10)		170°(H) x 160°(V) (Typ.) w/o sensor or glass
Lamp Life (hr) / Backlight		50,000 (Typ.) / CCFL
Stand Base		Tilt down : -5° , Tilt up : +90°
Input Signals		Analog, Digital
Signal Connector	Analog	D-Sub15 pin (VGA)
	Digital	DVI-D
Scan Frequency		60 ~ 75 Hz
Audio System		1W per channel
Touch Panel		5-wire Resistive
Touch Interface		RS-232 x1 or USB A type x1
Power		Universal Power Adapter Input AC 100 ~ 240V, 47 ~ 63Hz Output DC12V / 5.25A, 63W
Operating	Temperature	0°C ~ 40°C (32°F ~ 104°F)
	Humidity	10% ~ 90% (no condensation)
	Altitude	To 10,000 feet
Storage	Temperature	-20°C ~ 60°C (-4°F ~ 140°F)
	Humidity	10% ~ 90% (no condensation)
Dimensions (WxHxD)		392.0 x 381.5 x 180.0 mm
Carton Dimensions (WxHxD)		452.0 x 461.0 x 228.0 mm
Weight (Net)		6.5 kg
Certification	EMC	CE/FCC
	Safety	UL60601-1: ED.3 / EN60601-3.14
	Other	RoHS / WEEE
Standard Pallet Loading (by sea)		40 units (1140 [L] x 910 [W] x 1964 [H] mm)
Standard Pallet Loading (by air)		30 units (1140 [L] x 910 [W] x 1503 [H] mm)

FeATureS

- High contrast color TFT LCD display support resolution up to 1280 x 1024
- Compatible with VGA, IBM and VESA signal standards (resolution/timing auto-detected)
- Compatible with non-standard signals (on request)
- Supports DDC 1/2B for Plug & Play compatibility
- Advanced OSD control for picture quality adjustment
- VESA standard mounting
- RoHS Compliance

OpTIOnS

- Anti-Glare / Anti-Reflective tempered glass
- Sunlight Readable
- IP54 waterproof & dustproof sealed front bezel
- Touch sensor technologies: resistive, surface capacitive
- Video Signal input
 - Signal Connector: RCA / S-Video
 - NTSC / PAL / SECAM video

TOuch SeNSOr SpEcfIcATIOn

Type	5W Resistive	Capacitive
Transmission	80% ± 2%	91.5% ± 1.5%
Interface	USB or RS-232	USB or RS-232
Durability	30 million times	3-years
OS Support	DOS ; Windows Linux Mac OS X / OS 9.x	

* Specifications are subject to change without notice.

MechANicAl DrAwING

Unit : mm

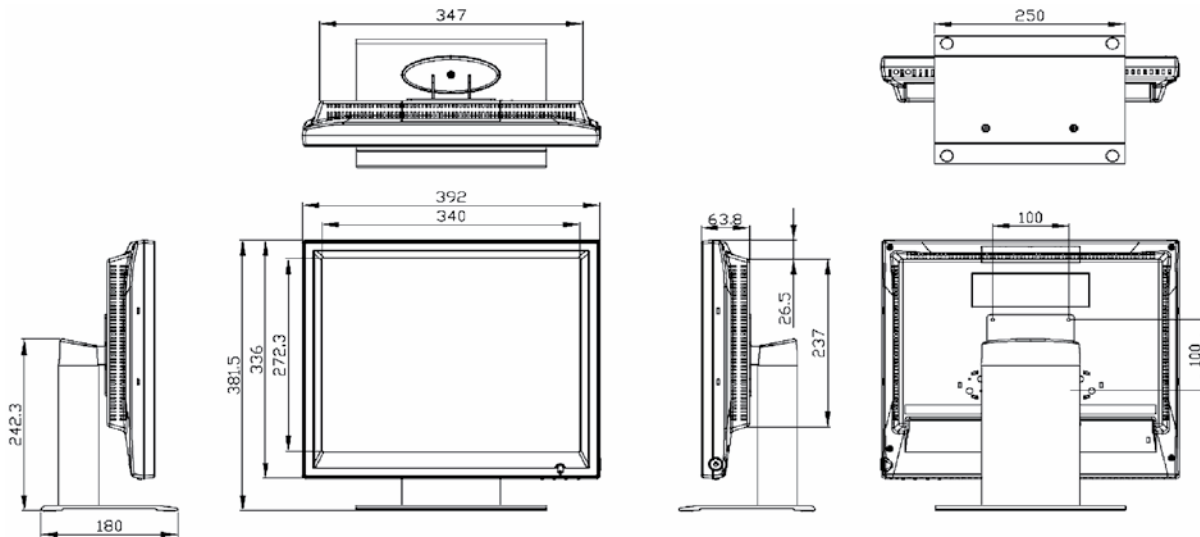

GVISION Inc. USA
20532 Crescent Bay Drive, Suite 104
Lake Forest, CA 92630

