

## 19" TFT LCD Display

# Medical Application



Where Versatility Meets Flexibility

## MA19BH

Configuration		MA19BH
LCD Display		19" TFT active matrix panel
Pixel Pitch		0.294 (H) x 0.294 (V) mm
Max. Resolution		SXGA 1280 x 1024
Contrast Ratio		1000:1 (Typ.) <small>w/o sensor or glass</small>
Brightness		400 cd/m <sup>2</sup> (Typ.) <small>w/o sensor or glass</small>
Response Time (Tr+Tf)		5 ms (Typ.)
Display Color		16.7M
Effective Display Area		376.4 (H) x 301.1 (V) mm
Viewing Angle (CR ≥ 10)		170°(H) x 160°(V) (Typ.) <small>w/o sensor or glass</small>
Lamp Life (hr) / Backlight		50,000 (Typ.) / CCFL
Stand Base		Tilt down : -5°, Tilt up : +90°
Input Signals		Analog, Digital
Signal Connector	Analog	D-Sub15 pin (VGA)
	Digital	DVI-D
Scan Frequency		60 ~ 75 Hz
Audio System		1W / per channel driver
Touch Panel		5 wire Resistive
Touch Interface		RS-232 x1 or USB A type x1
Key Control		Power on/off, with LED, Menu, Select, Adjustment (+,-)
Power		Universal 100~240V, 50~60 Hz 1.5A AC input
Operating Condition	Temperature	0°C - 40°C ( 32°F - 104°F )
	Humidity	10% - 90% ( no condensation )
	Altitude	To 10,000 feet
Storage Condition	Temperature	-20°C - 60°C ( -4°F - 140°F )
	Humidity	10% - 90% ( no condensation )
Dimensions (WxHxD)		438.0 x 417.5 x 180.0 mm
Carton Dimensions (WxHxD)		530.0 x 500.0 x 230.0 mm
Weight (Net)		8 kg
Certification		CE, FCC, UL60601-3.1

\* Specifications are subject to change without notice.

### Features

- ⊙ High contrast color TFT LCD display support resolution up to 1280 x 1024. Compatible with IBM, VGA, VESA standards.
- ⊙ Support DDC 1/2B for Plug & Play compatibility.
- ⊙ Advanced OSD control for picture quality adjustment.
- ⊙ Auto detects multi-signals input.
- ⊙ Optional front panel sealed to resist dust and splashes.
  - AG / AR tempered glass : IP54
  - Resistive / Capacitive Touch Panel : IP54
- ⊙ VESA mounting.
- ⊙ RoHS Compliance.

### Optional Accessories

- ⊙ Anti-Glare / Anti-Reflective tempered glass (MOQ) .
- ⊙ Capacitive Touch Solution (MOQ) .
- ⊙ Choice of black or white housing (MOQ) .
- ⊙ Video Signal input (MOQ) .
  - Signal Connector : RCA / S-Video
  - NTSC / PAL / SECAM video systems compatible .

### I / O Port

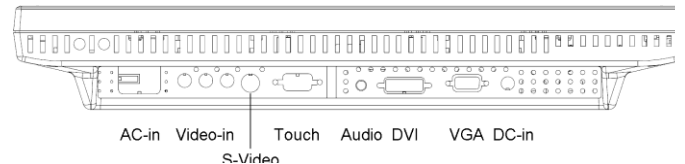

### Mechanical Drawing

Unit : mm

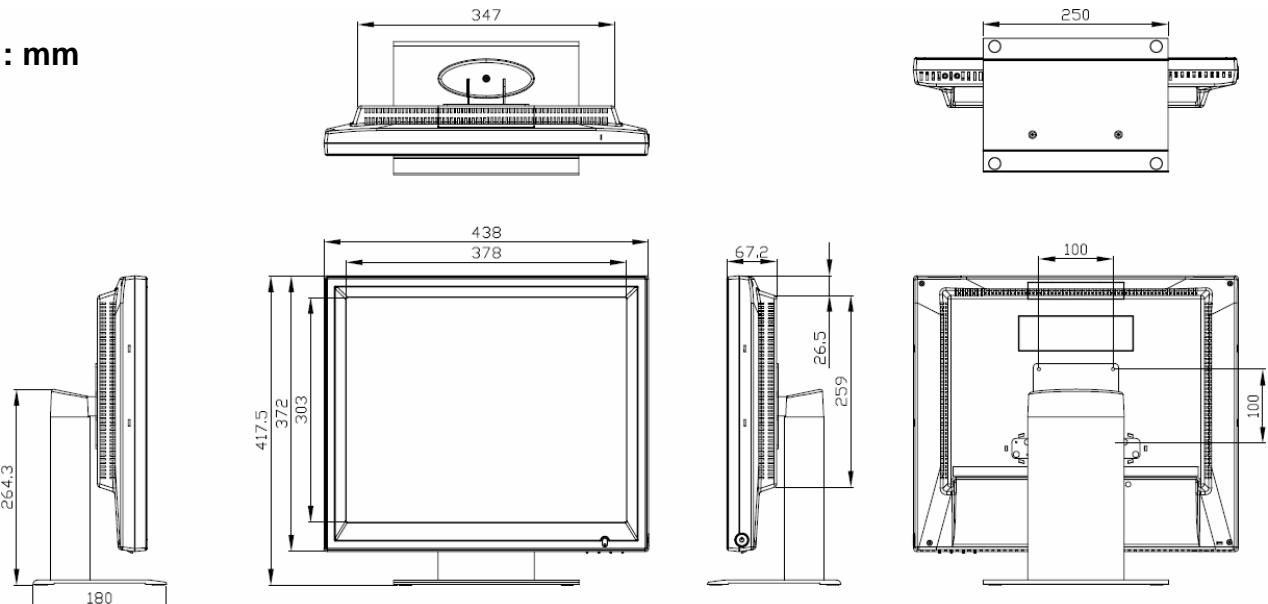

For more information please contact

Tel:+886-2-8226-1110 | Fax:+886-2-8226-1112 | www.GVISION.com.tw